

# A Path Analysis of the Relationship among Critical Motivational Variables and Achievement in Reform-Oriented Mathematics Curriculum

James A. Middleton, Aisling Leavy & Lars Leader

To cite this article: James A. Middleton, Aisling Leavy & Lars Leader (2013) A Path Analysis of the Relationship among Critical Motivational Variables and Achievement in Reform-Oriented Mathematics Curriculum, *RMLE Online*, 36:8, 1-10, DOI: [10.1080/19404476.2013.11462101](https://doi.org/10.1080/19404476.2013.11462101)

To link to this article: <https://doi.org/10.1080/19404476.2013.11462101>



Published online: 25 Aug 2015.



Submit your article to this journal [↗](#)



Article views: 47



Citing articles: 1 View citing articles [↗](#)

---

Karen Weller Swanson, Ed.D., Editor  
Mercer University  
Atlanta, Georgia

2013 • Volume 36 • Number 8

ISSN 1940-4476

## **A Path Analysis of the Relationship Among Critical Motivational Variables and Achievement in Reform-Oriented Mathematics Curriculum**

James A. Middleton  
Arizona State University  
Phoenix, AZ

Aisling Leavy  
Mary Immaculate College, University of Limerick  
Limerick, Ireland

Lars Leader  
Valdosta State University  
Valdosta, GA

### **Abstract**

This study investigated the relationship among critical motivational variables and mathematics achievement as middle grades students engaged in a reform-oriented curriculum, *Mathematics in Context*. We tested 327 students in fifth, sixth, and seventh grade before and after two years of implementation. We performed a path analysis with subscales representing latent motivational variables and with achievement on the Iowa Test of Basic Skills as the outcome variable. The variables stimulation and control interacted to produce task interest, which, in turn, contributed to achievement gains. Effort was a byproduct of the stimulation afforded by the mathematical tasks. Attributions of success and failure were outcomes of interest. Utility mediated the effort on tasks and the attributions the tasks engendered. Results show that, with curriculum designed to emphasize utility and interest, students forged a high degree of motivation. Also, their achievement increased dramatically, in part, as a function of this increase in motivation.

Historically, one of the most perplexing questions facing mathematics education researchers involves the complex interaction of variables impacting student learning and achievement. One of the goals of mathematics education research is to develop systems of teaching and learning that accelerate the growth of mathematical understanding and students' subsequent ability to use mathematics in science, engineering, business, and other applicational contexts. But, it seems that no matter what we do at scale, the vagaries of implementation, inconsistencies in curriculum and instruction, unequal distribution of resources, as well as cultural and political differences, conspire to thwart our best intentions (Coburn, 2003).

Part of our frustration originates from the fact that the causal models we employ in research are oversimplified to facilitate conceptualization while the treatments we design are too complex to fully comprehend. A contemporary example of this historical problem is that of National Science Foundation-sponsored curriculum. The model employed in most impact studies is modified down to a simple causal chain (see Figure 1, for example).

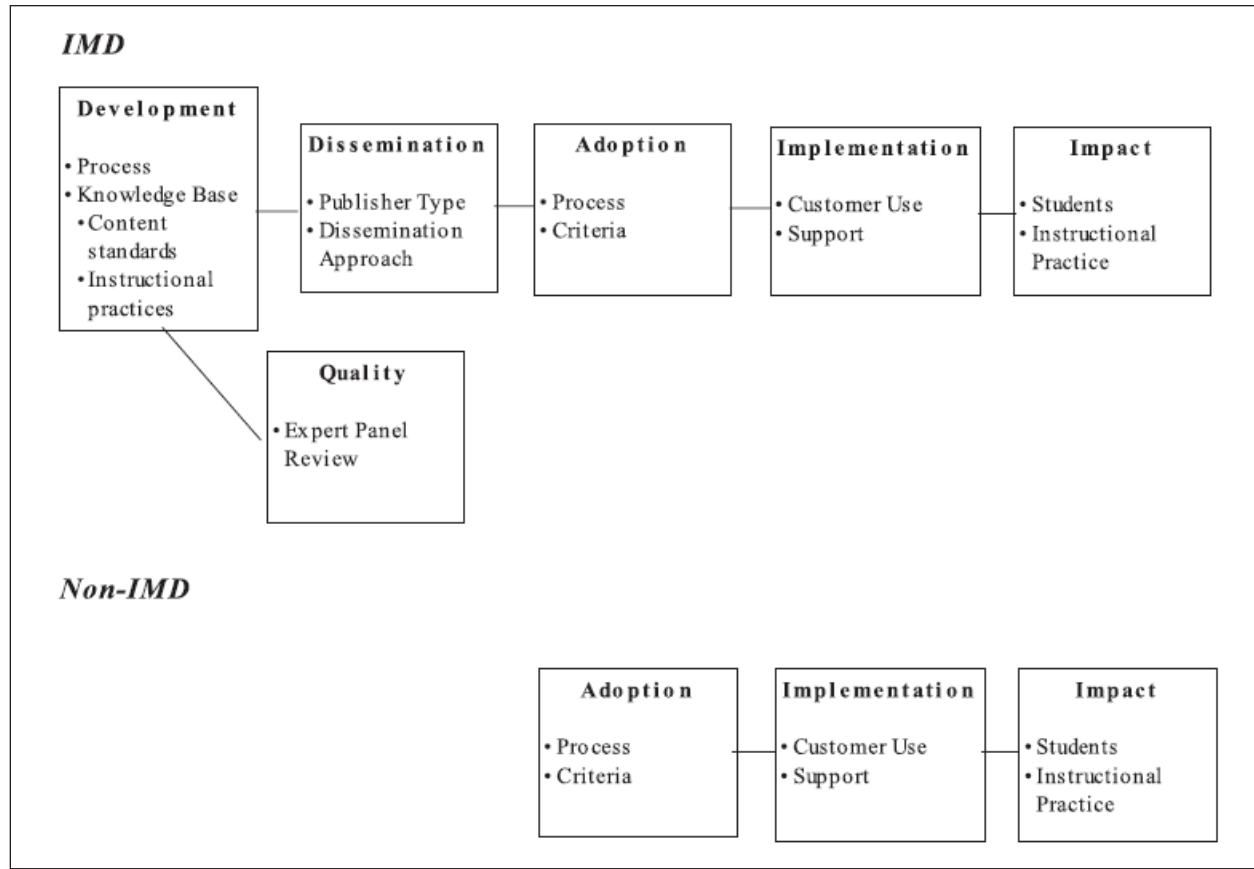

Figure 1. Evaluation Framework from Final Report on the Evaluation of the National Science Foundation's Instructional Materials Development Program (Tushnet, et al., 2000).

It is clear to any casual observer of the process of developing, testing, publishing, and adopting curriculum, that each of the boxes in Figure 1 are, in and of themselves, complex subsystems of a larger, multifaceted system that doesn't really resemble the direct causal chain shown. Feedback, for example, exists within each stage and also loops back from subsequent stages to earlier ones, as beta-versions of a product are trialed and revised. It is a wonder that we can make any impact at all through curriculum revision and associated professional development.

The study reported here examines one key aspect of the impact of reform-oriented curricula: the development of positive attitudes and motivation resulting from learning mathematics in a system that regularly emphasizes its utility, importance, coherence, and relevance. Instead of contextualized sidebars to formal mathematics instruction, reform-oriented curriculum, as a whole, considers the applications of mathematics as serious components of mathematical exploration, development, and rigor. It follows, then, that a major outcome of working with reform-oriented materials should be the

realization by students that mathematics can be and, in many cases, *is* interesting and useful (Middleton, 1999). Such realizations should not be taken lightly. After all, there is evidence to suggest that students believe mathematics is important for future jobs, the economy, science, and industry; however, it is clear that students also don't see mathematics as very important to them, their future, or their success (Middleton & Toluk, 1999). If attitudinal variables, such as utility and interest, are to be of any use to us at scale, there should be some significant causal relationship between such realizations and students' subsequent mathematical achievement.

There has been a long and rich debate about the degree to which achievement that children exhibit as a result of academic activities is impacted by *expectancies*, those feelings of personal agency in performing a task, and *values*, the degree to which the task itself and its outcomes and contingencies are considered worthwhile to pursue. In general, research suggests that both expectancies and values are important in mathematics achievement. Students use expectations of success to guide their degree

of involvement in immediate tasks. Nonetheless, these expectations, however much they impact any given situation in particular, are relatively unrelated to long-term engagement patterns, whereas the value students place on content seems to predict subsequent involvement and engagement in the field (Meece, Wigfield, & Eccles, 1990). This suggests that the tasks we design for students should match the students' abilities, the students also need to believe tasks to be both of utility and interest. The tasks should be facilitative of the development of value for mathematics, positive mathematical confidence, and self-efficacy (Middleton & Toluk, 1999; Pajares & Miller, 1994).

The purpose of this research was to investigate the relationship among a number of critical motivational variables and mathematics achievement as middle grades students engaged in a reform-oriented curriculum designed under a vastly different model of instruction than they had previously encountered.

We focus on Realistic Mathematics Education (RME) in this article (see deCorte, 1995), as it is the underlying theoretical structure for the studied curriculum, Mathematics in Context (Romberg 1997). Within that framework, we show that theoretically students should develop interest, perseverance, and success attributions when the mathematical experiences they engage in emphasize the following:

1. Progressive mathematization, whereby mathematical models are developed through the successive positioning of contexts that embody the underlying structure of concepts, leading to the development of importance-related beliefs (Wubbels, Korthagen, & Broekman, 1997).
2. Guided reinvention, whereby important mathematical concepts and representational forms are mediated by the materials and teacher, building a better sense of control and optimal stimulation in the student (Middleton, 1999; Leader & Middleton, 2004).
3. Bridging, whereby the transition from informal, everyday thinking to more formal, scientific thinking is facilitated by the introduction of powerful intermediary models such as the fraction bar, ratio table, or Cartesian system, building a set of useful and transferable ways of approaching and solving problems (Treffers, 1993; Middleton, Lesh, & Heger, 2002).

More specifically, in terms of common motivational constructs, the utility and connectedness of mathematical structure to everyday and fantastical situations is emphasized in the process of mathematization. Attention to personal models, explanations, and strategies is central to guided reinvention, and provision of appropriate challenge and control to the individual is facilitated through the introduction of intermediary models. These constructs have been shown to be related to the development of intrinsic motivation for academic tasks (Deci & Ryan, 1987). Moreover, applications of the theory of RME to large-scale curriculum development in the Mathematics in Context project has been shown to be a viable device for curricular design to maximize stimulation, control, and utility in mathematically rich, critical-thinking experiences (Leader & Middleton, 2004; Middleton & Roodhardt, 1997; Leader & Middleton, 2004; also see Romberg 1994 for a more complete discussion of the mathematical and pedagogical design principles).

Because these notions are highly interrelated theoretically, we used the adaptive model of motivation developed by Middleton & Toluk (1999) to generate the basic model for a confirmatory path analysis of the interactions among these variables and mathematics achievement over the two-year period of our study. For our purposes, we are interested here in the nature of the intrinsic portion of the hypothesized model presented by Middleton & Toluk (1999), which has not yet been tested empirically. In that model, tradeoffs between the stimulation and control afforded by tasks significantly determine the level of interest exhibited by students in an activity. That interest leads students to deeper and longer engagement in the activity at hand, which, in turn, contributes significantly to levels of achievement. Moreover, the utility afforded by tasks contributes significantly to students' task-level interest. Therefore, tasks that are consistently seen as useful and that contain the potential for the development of interest may contribute to ability attributions and increased effort if the tasks are of sufficient mathematical depth and complexity (c.f., Leader & Middleton, 2004).

As a rigorous test of theory, our argument has two primary facets. First, these critical variables interact significantly in influencing a student to expend effort, engage persistently, learn more, and, subsequently, perform better on tests of their mathematical achievement. Second, engagement in mathematics curricula that conform reasonably well to the positive

poles of these variables should influence students to achieve better and to value mathematics more than the general population. We tested both of these assertions in this study.

**Method**

We tested 327 middle school students (147 males and 180 females) in grades 5–7 drawn from a large Midwestern school district prior to their involvement in the Mathematics in Context curriculum and again after two years of implementation of Mathematics in Context.

**Instrument**

There was no instrument designed to assess all areas of motivation in which we were interested. We therefore designed an instrument to garner information about different types of students’ motivational attitudes toward mathematics that have been shown to be theoretically defensible, practically relevant, and highly interconnected in determining overall motivation toward learning mathematics. The instrument used items adapted from those developed earlier by other researchers: The Children’s Academic Intrinsic Motivation Inventory (Gottfried, 1985); the Mathematics Attitudes Scales (Fennema & Sherman, 1976); Middleton, Littlefield, & Lehrer’s (1992) listing of middle school students’ personal constructs; and Schoenfeld’s (1989) study of students’ mathematical beliefs. Each of the source publications for the battery of items reports defensible psychometrics, and our subsequent development showed high internal consistency within subscales (Leader, Middleton, & Leavy, 1999). Please note that modifications were made to item wording to match the nature of the Mathematics in Context project, and items from different sources often appear in the same subscale (see Table 1).

**Procedure**

The students were tested prior to instruction and again after two years of involvement in the project. (Note: The *n* of 327 in the sample includes only those students who were enrolled throughout both years). Reliabilities for all eight subscales were moderate to very high (*M* of Chronbach’s alpha = .79). Mathematics performance was measured using the Iowa Test of Basic Skills and a district administered algebra aptitude examination. Each of the four semesters of the project, observations of classrooms were made during one-week site visits.

The RME-based curriculum was taught in all district middle grades classrooms for two full years, constituting a complete replacement of the district’s mathematics program. As a result of their involvement, students attitudes were expected to improve in each of the eight subscales (attribute, challenge, confidence, control, effort, interest, stimulation, and utility), and achievement was expected to show a concomitant growth.

**Results**

Descriptive statistics for each subscale showed no outliers. Cross-sectional results from the first administration showed the typical downward trend in attitudes reported in other studies of attitudes and achievement for middle grades students. In the first administration, students in higher grades exhibited successively lower motivation toward mathematics (see Eccles et al., 1993). However, for the second administration, examination of mean scores showed an increase for six of the seven attitude subscales. Mean scores for confidence, control, effort, interest, stimulation, and utility increased significantly from the first administration of the instrument to the second administration. This suggests that students experienced greater feelings of confidence, control,

Table 1  
*Sample Items Assessing Latent Variables in the Structural Equations Model*

| Scale        | Sample Items   |
|--------------|--|
| Interest     | Mathematics is interesting.<br>Mathematics is one of my interests.<br>Mathematics is challenging. (stim)<br>I have choices of things to do in mathematics. (control)                 |
| Utility      | Mathematics is useful.   |
| Attributions | When I figure out how to do a mathematics problem, it is because I am smart. (ability)<br>When I understand how to do a problem in mathematics, it is because I tried hard. (effort) |
| Confidence   | I am confident in mathematics.   |
| Effort       | I work hard in mathematics.  |

and interest in mathematics; increased effort in attempting mathematical problems; increased stimulation when doing mathematics; and increased belief in the utility of mathematics.

A repeated measures ANOVA was carried out to investigate whether there was any significant difference in the subscales scores across time (See Table 1). Significant differences across time were found for confidence ( $F = 16.635, p < .001$ ), control ( $F = 15.198, p < .001$ ), effort ( $F = 6.614, p < .05$ ), interest ( $F = 13.824, p < .001$ ), stimulation ( $F = 34.251, p < .001$ ), and utility ( $F = 16.592, p < .001$ ).

Repeated measures ANOVA were also carried out on four questions that were not categorized into any of the subscales. Significant gains were found for amount of time spent on typical homework problems ( $F = 75.0414, p < .001$ ), and students' notions of a reasonable amount of time to work on a problem before the student knows it is impossible ( $F = 50.26, p < .001$ ). Both of these items were used to assess change in perseverance on difficult tasks. Significant gains were also found for ratings of the importance of doing a school assignment for the sake of learning over obtaining good grades ( $F = 43.733, p < .001$ ) and preferences for learning new content versus repeating content learned already ( $F = 353.216, p < .001$ ). Because these variables have a smaller body of research linking them to the primary variables in the study, they were not included in the path analyses. However, these items were used to gauge, from a curriculum designer's perspective, whether or not interest, stimulation, control, and the other important variables for forming intrinsic motivation in mathematics were aligned with what are valued as work habits and disposition toward learning mathematics.

Changes in student achievement were measured using scores on two mathematical tests. Seventh grade students' mathematics scores on the Iowa Test of Basic Skills (ITBS) were collected for five consecutive years. ITBS consists of measures of mathematical concepts, mathematical problem solving, and computational skills. The scores for the first year would reflect achievement of students who had not been taught the curriculum. The scores from ITBS data show a steady positive increase over the years of implementation. The mean scores from Year 1 to Year 5 increased on mathematical concepts 66.28, 68.39, 68.11, 70.56, and 72.17, respectively), mathematical problem solving (70.98, 74.63, 69.53, 75.14, and 74.97, respectively), and computation (44.8, 59.76, 56.67, 61.03, and 59.80, respectively).

The Iowa Algebra Aptitude Test was employed to measure students' ability to reason algebraically. The scores were collected for seventh graders over five years (1993–1997). Again, scores for earlier years were for students who had no experience with the curriculum. The later the year, the more years of instruction students had with the curriculum. The mean algebra score increased from 37.00 in Year 1 to 42.90 in Year 5. A one-way ANOVA revealed that these changes were statistically significant ( $F = 13.2, p < .001$ ).

**Path Analysis**

To examine the interactions among motivational variables and achievement gains, we performed a path analysis with subscales representing latent motivational variables and achievement on the ITBS as the outcome variable. To carry out the structural equations model, the correlation and covariance matrices for the input variables for the total sample

Table 2  
*Correlation Matrix for the Eight Measured Variables*

| Variable | V 1    | V 2    | V 3    | V 5    | V 6    | V 7    | V 8    | V 9   |
|----------|--------|--------|--------|--------|--------|--------|--------|-------|
| V 1      | 1.000  |        |        |        |        |        |        |       |
| V 2      | -0.115 | 1.000  |        |        |        |        |        |       |
| V 3      | 0.641  | -0.081 | 1.000  |        |        |        |        |       |
| V 5      | 0.731  | -0.093 | 0.653  | 1.000  |        |        |        |       |
| V 6      | -0.036 | 0.318  | -0.026 | -0.030 | 1.000  |        |        |       |
| V 7      | 0.375  | -0.017 | 0.329  | 0.503  | -0.006 | 1.000  |        |       |
| V 8      | 0.053  | 0.227  | 0.000  | 0.000  | 0.072  | 0.129  | 1.000  |       |
| V 9      | -0.058 | 0.007  | -0.037 | -0.043 | 0.002  | -0.022 | -0.003 | 1.000 |

Note: V1 = attributions, V2 = challenge, V3 = confidence, V5 = effort, V6 = interest, V7 = stimulation, V8 = utility and V9 = mathematics achievement

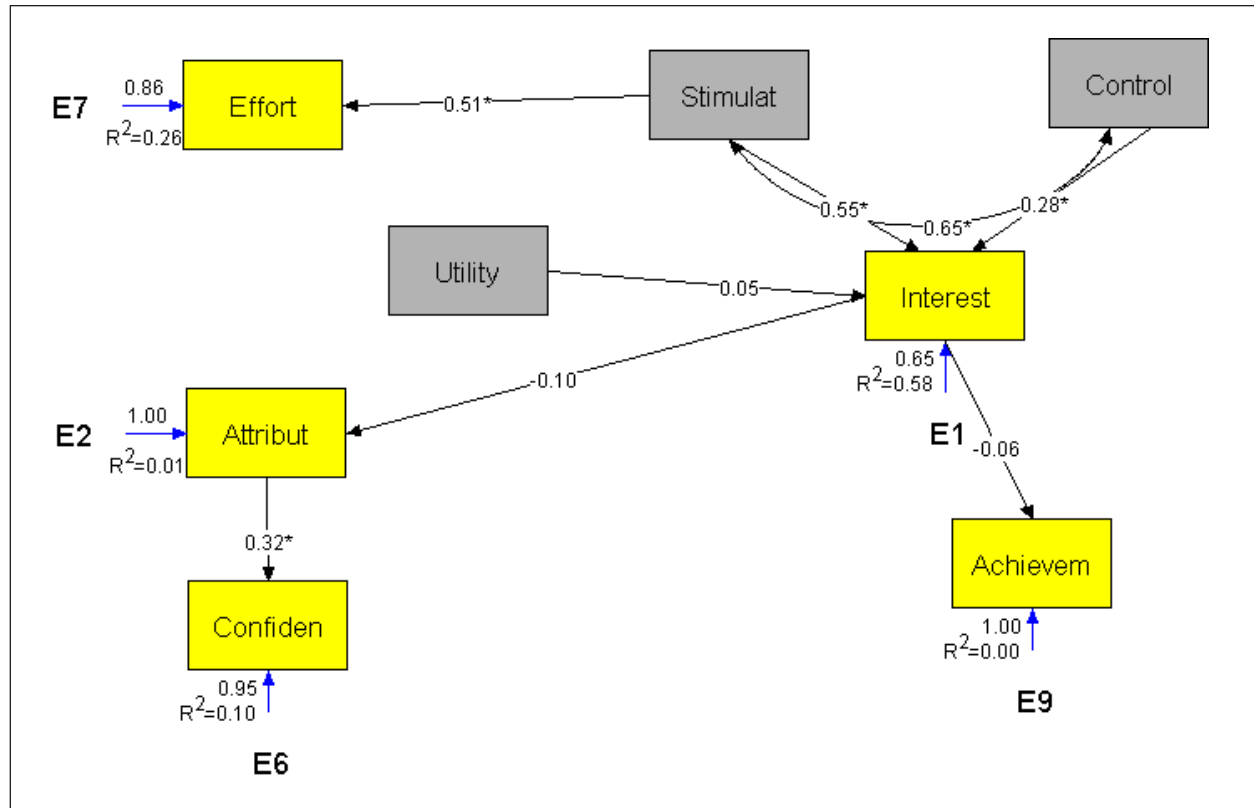

Figure 2. Hypothesized Path Model of Seven Critical Variables Impacting Mathematics Achievement.

were computed. The covariance matrix was used to perform maximum likelihood linear structural relations analyses. The EQS Multivariate Software was used for these analyses. Due to the raw data originating from a Likert scale, robust statistics were used. The intercorrelation of the input variables can be seen in Table 2.

**Model 1: A test of the theory.** Our first pass at the data took Middleton & Toluk’s (1999) hypothesized structure for the development of interest and used it as the initial model to be tested. This model hypothesized that interest would be influenced, indeed nearly would be defined, by an interaction between stimulation and control. In addition, utility was assumed to contribute to interests because it ties tasks to the immediate needs of the child. Achievement was naively assumed to flow directly from interests (Middleton & Toluk, 1999). Interests is a construct that defines whether or not a task will be engaged in or not, barring extrinsic rewards or punishments, and, therefore, was thought to directly predict achievement. Effort was assumed to be derived from stimulation, while attribution was assumed to derive from interests and instill confidence.

These hypotheses are shown in Figure 2 as the arrows between latent variables. Analysis of the hypothesized path model resulted in comparative fit index (CFI) of 0.92. (A CFI of 0 indicates total lack of fit of the model, while a CFI of 1 indicates that the specified model fits the data perfectly). Chi-square analysis,  $\chi^2 (= 327) = 69.21$ , indicated that the model did not fit the data perfectly. The RMSEA (root mean squared error of approximation) was 0.09 (see Figure 2).

As predicted by the Middleton & Toluk (1999) model, stimulation and control interacted significantly to produce task interest, which, in turn, directly contributed to achievement gains over the two-year implementation period. Effort was shown to be a direct byproduct of the stimulation afforded by the mathematical tasks (harder tasks required more effort). Attributions (scaled toward internal, stable attributions of success), as predicted, loaded significantly as outcomes of interest, presumably because Interests is an evaluative construct, recording the outcomes of activity. Under this model, given the retrospective nature of the attributions scale used in this study, attributions can be thought of as labels placed on previously evaluated activity.

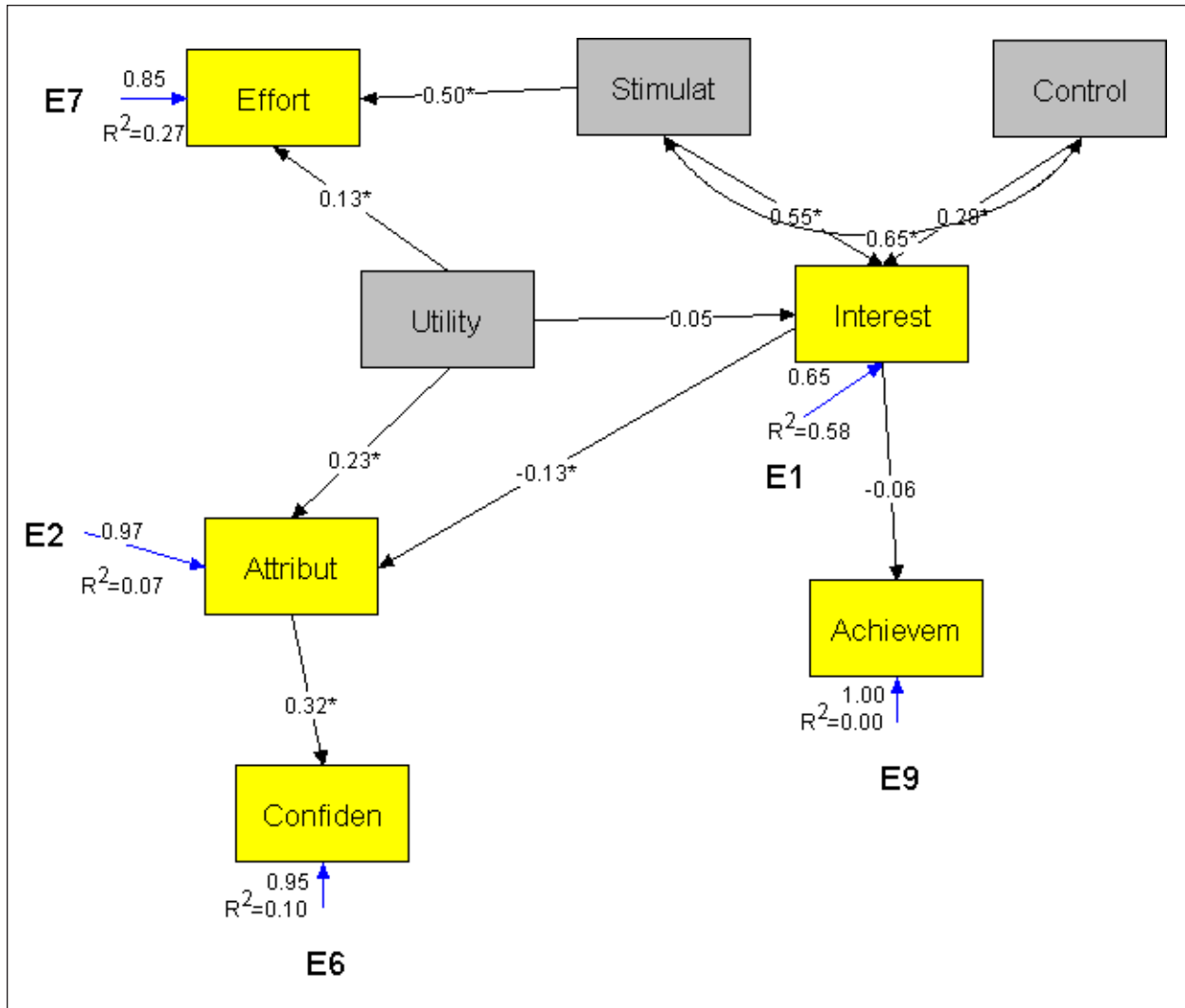

Figure 3. Modified Path Model Showing the Mediational Role of Utility between Effort and Internal, Stable Attributions

**Model 2: Respecification of variables to modify the original model to better fit the data.** While the confirmatory analysis showed the theory developed by Middleton & Toluk (1999) to be descriptive of the relationships among latent variables predicting motivation and achievement, the modification indices of one of the variables, utility, suggested respecification of the model. Introducing two new free parameters for estimation would substantially reduce the chi-square value and the RMSEA value while increasing the Goodness of Fit Index (GFI) and Adjusted Goodness of Fit Index (AGFI). The modified model was examined. It resulted in better fit ( $\chi^2 = 43.73$ , CFI = 0.96, RMSEA = 0.07). Figure 3 shows these modifications.

The important changes of note specify the mediational role of task utility in determining the effort expended in a task and its role in mediating the

attributions of success and failure the task engenders. The core of the hypothesized model, however, remained unchanged.

### Discussion

As a test of a relatively complex theory of the development of interests and the effect of developing interest on growth in achievement, the results of this study support the general model developed by Middleton & Toluk (1999) with one exception: Perceived utility was found to be much more integral to the development of success attributions and effort than originally hypothesized, serving an important mediational role between effort expended on a task and attributions of success and failure, ultimately leading to feelings of confidence in mathematics. This finding is significant, in that it blurs the distinction between intrinsic motivation (doing



something for its own sake) and extrinsic motivation (doing something for its reinforcement value). It seems likely that people look at tasks somewhat differently than hypothesized. It may be that, in academic coursework, people develop a kind of motivation to engage in tasks for their own sake.

The causal structure of the path analysis, documents rather convincingly, we think, that stimulation and control conditions are codependent upon each other and together directly influence the development of interest and subsequent engagement and achievement in mathematical tasks. The relatively low loadings between what we consider to be factors contributing to intrinsic motivation (e.g., interests) and factors contributing to extrinsic motivation (e.g., utility) lends additional support for the hypothesized function of interests as the link between an extrinsic evaluation system and an intrinsic system.

From a curriculum design standpoint, results reveal that the ways in which motivational domain activities were built into students' experiences greatly influenced their beliefs about the nature of mathematics and what makes it motivating. Students' ratings for each of the domains tested rose significantly over the two years, with moderate to large effect. This is striking, considering that in the first administration the students exhibited the traditional downward curve: motivation toward mathematics tended to decrease as a function of age. With curriculum designed to emphasize utility and interest, involvement in meaningful activity positively influenced students to forge a relatively high degree of motivation over the two-year period. In addition, student performance on mathematics achievement increased dramatically over the period of instruction, in part, as a function of this increase in motivation.

Table 3  
*Gains in Attitudes as a Result of Engagement in Mathematics in Context*

| Subscale    | Mean Score |        |
|-------------|------------|--------|
|             | Year 1     | Year 2 |
| Confidence  | 3.03       | 3.18   |
| Control     | 2.94       | 3.13   |
| Effort      | 3.13       | 3.23   |
| Interest    | 3.03       | 3.17   |
| Stimulation | 3.18       | 3.41   |
| Utility     | 2.95       | 3.07   |

Note: All *p*-values <.05

This study provides evidence that curriculum can be designed for relatively long-term improvement in motivation and achievement in mathematics. Results of this research suggest that the principles of curriculum design that maximize the motivation of students to learn sound and significant mathematics in the middle grades were fostered in the RME-based curriculum, *Mathematics in Context*. In particular, we maintain that we provided students with the opportunity to engage in significant, ill-structured problem solving, heightening their sensitivity to important information, augmenting their inclination (interest) to engage in significant mathematical tasks, which subsequently capitalized on, and improved, their ability to solve relevant, meaningful tasks.

Evidence from large-scale studies indicates that motivation and achievement are critically interdependent developmentally. In mathematics, children become more homogeneous with respect to motivation and achievement over time, not more diverse (Gottfried, Marcoulides, Gottfried, Oliver, & Guerin, 2007). The fact that in the U.S. general population students tend to grow more disillusioned and less likely to continue on in higher levels of mathematics and show diminishing returns on achievement suggests that serious attention must be paid to designing appropriate interventions to counteract this trend. The education enterprise is just not stimulating an appropriate proportion of the population to develop either interest- or utility-related valuations for mathematics in or beyond school (Wigfield, Eccles, Schiefele, Roeser, & Davis-Kean, 2006).

The relatively small impact of growth in interests on achievement outcomes suggests that achievement is dependent on other cognitive factors (e.g., prior achievement) and situational variables (high-quality content and teaching), indicating that coherent, consistent, and stimulating experiences build a productive disposition to engage in mathematics and achievement gradually over many years.

Certainly, as the curriculum was being designed, creators of *Mathematics in Context* paid careful attention to mathematical structure and development, much more so than the attention they paid to motivation and other dispositional variables (Romberg, 1994). This realization is important because, even though our results suggest that motivational aspects of curricular innovation can dramatically improve students' motivation to learn, their achievement is dependent on many more pieces of the puzzle falling into place.

## References

- Brophy, J. (1987). Socializing students' motivation to learn. In M. L. Maehr & D. A. Kleiber (Eds.), *Advances in motivation and achievement* (Vol. 5, pp. 181–210). Greenwich, CT: JAI Press.
- Coburn, C. E. (2003). Rethinking scale: Moving beyond numbers to deep and lasting change. *Educational Researcher*, 32(6), 3–12.
- Deci, E. L., & Ryan, R. M. (1987). The support of autonomy and the control of behavior. *Journal of Personality and Social Psychology*, 53, 1024–1037.
- DeCorte, E. (1995). Fostering cognitive growth: A perspective from research on mathematics learning and instruction. *Educational Psychologist*, 30(1), 37–46.
- Eccles, J., Wigfield, A., Midgley, C., Reuman, D., Mac Iver, D., & Feldlaufer, H. (1993). Negative effects of traditional middle schools on students' motivation. *Elementary School Journal*, 93, 553–574.
- Fennema, E., & Sherman, J. A. (1976). Fennema-Sherman Mathematics Attitude Scales: Instruments designed to measure attitudes toward the learning of mathematics by females and males. *Journal for Research in Mathematics Education*, 7, 324–326.
- Gagné, R. M. (1977). *The conditions of learning* (3rd ed.). New York, NY: Holt, Rinehart and Winston.
- Gottfried, A. E. (1985). Academic intrinsic motivation in elementary and junior high school students. *Journal of Educational Psychology*, 77, 631–645.
- Gottfried, A. E., Marcoulides, G. A., Gottfried, A. W., Oliver, P., & Wright Guerin, D. (2007). Multivariate latent change modeling of developmental decline in academic intrinsic math motivation and achievement: Childhood through adolescence. *International Journal of Behavioral Development*, 31, 317–327.
- Leader, L. F., & Middleton, J. A. (2004). From ability to action: Designing instruction for critical thinking dispositions. *Research in Middle Level Education Online*, 28(1). Retrieved from <http://www.nmsa.org/Publications/RMLEOnline/tabid/101/Default.aspx>
- Leader, L., Middleton, J. A., & Leavy, A. (1999, April). From Ability to action: designing instruction for critical thinking dispositions. Paper presented at the Annual Meeting of the American Educational Research Association, Montreal, Canada.
- Mathematics in Context. (1998). *Teacher resource and implementation guide*. Chicago, IL: Encyclopedia Britannica Educational Corporation.
- Meece, J. S., Wigfield, A., & Eccles, J. S. (1990). Predictors of math anxiety and its consequences for young adolescents' course enrollment intentions and performances in mathematics. *Journal of Educational Psychology*, 82, 60–70.
- Middleton, J. A., Littlefield, J., & Lehrer, R. (1992). Gifted students' conceptions of academic fun: An examination of a critical construct for gifted education. *The Gifted Child Quarterly*, 36(1), 38–44.
- Middleton, J. A. (1999). Curricular influences on the motivational beliefs and practice of two middle school mathematics teachers: A follow-up study. *Journal for Research in Mathematics Education*, 30, 349–358.
- Middleton, J. A., & Roodhardt, A. (1997). Using knowledge of story schemas to structure mathematical activity. *Current Issues in Middle Level Education*, 6(1), 40–55.
- Middleton, J. A., & Spanias, P. (1999). Motivation for achievement in mathematics: Findings, generalizations, and criticisms of the recent research. *Journal for Research in Mathematics Education*, 30, 65–88.
- Middleton, J. A., & Toluk, Z. (1999). First steps in the development of an adaptive, decision-making theory of motivation. *Educational Psychologist*, 34(2), 99–112.
- Middleton, J. A., Lesh, R., & Heger, M. (2002). Interest, identity, and social functioning: Central features of modeling activity. In H. Doerr & R. Lesh (Eds.), *Beyond constructivism: A models & modeling perspective on mathematics problem solving, learning and teaching* (pp. 405–431). Mahwah, NJ: Lawrence Erlbaum.
- Pajares, F., & Miller, D. (1994). Role of self-efficacy and self-concept beliefs in mathematical problem solving: A path analysis. *Journal of Educational Psychology*, 86, 193–203.
- Romberg, T. A. (Ed.). (1994). *A blueprint for maths in context: A connected curriculum for grades 5–8*. Chicago, IL: Encyclopedia Britannica Educational Corporation.
- Romberg, T. A. (Ed.). (1997). *Mathematics in context: A connected curriculum for grades 5–8*. Chicago, IL: Encyclopedia Britannica Educational Corporation.

- Treffers, A. (1993). Wiskobas and Freudenthal: Realistic mathematics education. *Educational Studies in Mathematics*, 25, 89–108.
- Tushnet, N. C., Millsap, M. A., Abdulla-Welsh, N., Brigham, N., Cooley, E., Elliot, J., Johnston, K., Martinez, A., Nierenberg, M., & Rosenblum, S. (2000). *Final report on the evaluation of the National Science Foundation's instructional materials development program*. Washington, DC: National Science Foundation.
- Wigfield, A., Eccles, J. S., Schiefele, U., Roeser, R. W., & Davis-Kean, P. (2006). Development of achievement motivation. In N. Eisenberg (Ed.), *Handbook of child psychology: Vol 3. Social, emotional, and personality development* (6th ed., pp. 933–1002). New York, NY: Wiley.
- Wubbels, T., Korthagen, F., & Broekman, H. (1997). Preparing teachers for realistic mathematics education. *Educational Studies in Mathematics*, 32, 1–28.